

METALTECH[®] automEX

Co-locating:

15 - 18 MAY 2024 MITEC, KUALA LUMPUR

SHOW DAILY

15 - 17 May 2024 | 10am-6pm
18 May 2024 | 10am-4pm

www.metaltech.com.my | www.automex.com.my

Organised by:



METALTECH & AUTOMEX



METALTECH & AUTOMEX 2024

Continues to Drive Malaysia's

INDUSTRY 4.0 REVOLUTION



The 28th International Machine Tools, Metalworking and Automation Technology Exhibition, METALTECH & AUTOMEX 2024, kicked off with a dazzling opening ceremony at the Malaysia International Trade and Exhibition Centre (MITEC). The event, which runs from 15 – 18 May 2024, is poised to be a major driver of Malaysia's manufacturing future by showcasing the latest advancements in Industry 4.0 technologies.

The opening ceremony was officiated by YBhg. Datuk Hanafi Sakri, Deputy Secretary General (Industry) of the Ministry of International Trade and Industry (MITI). He was joined by Organising Chairman of Informa Markets Malaysia, YBhg. Tan Sri Dato Sri Dr Hj Mohd Nasir Bin Mohd Ashraf, Chairman of METALTECH & AUTOMEX, YBhg. Dato Dr Tan Chin Huat, and Country General Manager of Informa Markets Malaysia, Mr. Gerard Leeuwenburgh. Their presence highlighted the importance of METALTECH & AUTOMEX as a platform for growth and innovation in Malaysia's manufacturing sector.

Datuk Hanafi's keynote address highlighted the impressive growth of Malaysia's manufacturing sector. In 2023, investments surged to RM152.0 billion, a remarkable 80.3% increase compared to the previous year. Strong foreign and domestic investments demonstrated both investor confidence in Malaysia and the country's resilience in a surprisingly positive global economic climate. He emphasised the role of METALTECH & AUTOMEX in propelling Malaysia towards becoming a regional leader in smart manufacturing, advanced technologies, and high-tech industries.

"This year's theme perfectly aligns with Malaysia's vision for industrial development as outlined in the New Industrial Master Plan 2030 (NIMP 2030). This plan emphasises adopting advanced technologies and

digitalisation across all sectors. METALTECH & AUTOMEX serves as a crucial platform to empower domestic manufacturers by showcasing cutting-edge technologies, fostering collaboration, and facilitating knowledge sharing, said Datuk Hanafi Sakri.

"The future of manufacturing isn't just about machines, it's about the intelligent ways we use them. The industry is undergoing a period of unprecedented transformation. We're witnessing disruptive technologies like artificial intelligence, robotics, and the Internet of Things (IoT), fundamentally reshaping how we design, produce, and deliver products. These advancements present both challenges and opportunities. Embracing them isn't optional, it's a necessity," said Dato Dr Tan Chin Huat.



THANKS FOR THE EPIC TURNOUT!

We are deeply grateful for the overwhelming support shown by buyers and visitors at METALTECH & AUTOMEX 2024! Your enthusiasm and active participation have brought an electrifying energy to the event, showcasing the immense passion that propels our industry forward.

LET'S FORGE CONNECTIONS, FOSTER INNOVATION, AND DRIVE TRANSFORMATION.



METALTECH[®] automEX

Co-locating:

15 - 18 MAY 2024 MITEC, KUALA LUMPUR

SHOW DAILY

15 - 17 May 2024 | 10am-6pm
18 May 2024 | 10am-4pm

www.metaltech.com.my | www.automex.com.my

Organised by:



f in @ METALTECH & AUTOMEX



Unveiling the future INNOVATIVE PRODUCT LAUNCHES

METALTECH & AUTOMEX 2024 is thrilled to be the platform of choice for industry leaders to unveil their groundbreaking new products. We were especially honoured to have Aliran Tenaga Technology Sdn. Bhd. leading the charge with their exciting product launch. Their presence is a testament to the calibre of innovation on display at our event. But this is just the beginning! Numerous other industry giants have chosen our event to showcase their latest cutting-edge technologies. We're confident these advancements will have a transformative impact on the future of manufacturing.

▶▶▶▶▶



EXPLORE DISRUPTIVE INDUSTRY

TRANSFORMATIONS

METALTECH & AUTOMEX 2024 empowered attendees to sharpen their expertise and stay ahead of the curve! Engaging seminar sessions, presented by leading industry innovators, offered a wealth of knowledge. Attendees explored the latest technology trends and advancements, gained valuable insights, and networked with fellow professionals, making it a truly enriching experience.



Don't miss out!
Tomorrow marks
the final day of seminars!

LET'S CELEBRATE! METALTECH & AUTOMEX 2024 EXHIBITOR APPRECIATION NIGHT

Flaring lights, pumping beats, and a room buzzing with connections – that's what went down at the unforgettable METALTECH & AUTOMEX 2024 Exhibitor Appreciation Night! We indulged in a feast fit for industry titans, roared with laughter at the electrifying entertainment, and celebrated the incredible exhibitors who made this event possible.



METALTECH[®] automEX

Co-locating:

15 - 18 MAY 2024 MITEC, KUALA LUMPUR

SHOW DAILY



AIR LIQUIDE MALAYSIA SDN BHD
BOOTH NO.: 3345



ARCAL™ Series



Experience exceptional gas solutions for your everyday welding requirements, combining simplicity and superior performance. Presenting our cutting-edge ARCAL™, a ready-to-weld solution, complemented by the innovative EXELTOP built-in regulator. Meticulously engineered to prioritize reliability and efficiency, our products cater to a wide range of welding needs, ensuring optimal outcomes in your welding endeavors.

AIRGENS MACHINERY SDN BHD

BOOTH NO.: 8200



ACP - 10HP OIL FREE SCROLL AIR COMPRESSOR

The oil-free scroll air compressor is the latest advancement in air compression technology. Our ACP oil-free scroll air compressors are characterized by their compact size, lightweight construction, low noise level, long lifespan, smooth and continuous air delivery, and minimal maintenance costs.



AOTAI ELECTRIC CO., LTD
BOOTH NO.: 3110



Experience the versatility of our Inverter MMA, TIG, MIG, SAW, Water Cooling Machine, and Air Plasma Cutter. Achieve exceptional results with simplicity, reliability, and high performance and elevate your welding projects to new heights. Meet us at Booth 3310 and witness our transformative welding solutions!



WELDERS

AZENTIO SOFTWARE SDN BHD
BOOTH NO.: 6366

Singapore-headquartered
Azentio Software



ONEERP

Singapore-headquartered Azentio Software is a market-leading provider of ERP systems. The company currently serves over 500 industrial enterprises in MEA and APAC, which are using the next-gen ONEERP Manufacturing Cloud to manage all the key areas of their manufacturing processes. With an innovative Industry 4.0 approach, ONEERP leverages a highly scalable Industry Cloud equipped with API-integrated ecosystems like IoT, MES, and more to intelligently address critical challenges faced by organizations in digital manufacturing.

Calculate your CO2 emissions

Powered by Monitor ERP

Visit us at Booth 7170, Hall 7, Level 2



22 kg CO₂e

5 kg CO₂e

15 kg CO₂e

9 kg CO₂e

17 kg CO₂e

13 kg CO₂e

+60 4 371 7816 | @monitorerpasia

BODOR INC.
BOOTH NO.: 4160



P6

The Bodor P Series sheet metal laser cutting machines represent the pinnacle of cutting-edge laser technology and exceptional performance. The craftsmanship, automation features, and safety measures of our P Series have been meticulously refined to deliver an unparalleled cutting experience.

METALTECH[®] automEX

Co-locating:

15 - 18 MAY 2024 MITEC, KUALA LUMPUR

SHOW DAILY



FALCON EQUIPMENT TECHNOLOGY SDN BHD
BOOTH NO.: 4265

HEXAGON MANUFACTURING INTELLIGENCE
BOOTH NO.: 2120



WUHAN SC LASER

At FETSB, we prioritize simplifying the process of buying, selling, and repairing machines. We understand that purchasing a machine entails a substantial investment, which is why we provide guidance and share our knowledge with customers, empowering them to make well-informed decisions.

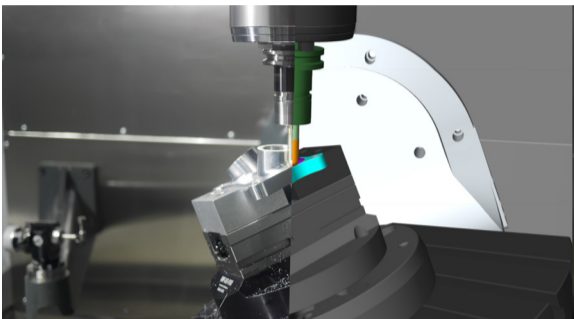

MEASUREMENT, SIMULATION AND AUTOMATION SOLUTIONS

Hexagon MI delivers metrology and manufacturing solutions, empowering industries to achieve new levels of precision and efficiency. Their range of technologies, from 3D laser scanners to automated CMMs (Coordinate Measuring Machines), ensures precise measurements that enhance quality control and streamline production processes.

ISQ HOLDINGS SDN BHD
BOOTH NO.: 8360

IWATANI MALAYSIA SDN BHD
BOOTH NO.: 6130



Abrasives | Tools & Equipment | Personal Protective Equipment (PPE) | Tapes & Adhesives | Paint Spray Equipment | Industrial Vending Solution

www.isqholdings.com

SAFETY & INDUSTRIAL PRODUCTS

We provide a wide selection of safety and industrial products, partnering with top brands committed to quality. Our extensive product range includes Abrasives, Personal Protective Equipment, Tools & Equipment, Tapes & Adhesives, Paint Spray Equipment, and Vending Solutions.



Iwatani
Iwatani Malaysia Sdn. Bhd.

YASKAWA INDUSTRIAL ROBOT

YASKAWA INDUSTRIAL ROBOT offers robotic solutions for spot and arc welding, press-handling, and explosion-proof painting, as well as specialized robots for conveyor handling, palletizing, and collaborative work with human operators, enhancing efficiency and safety in industrial environments.

MALAYSIA METALTECH

MALAYSIAN INTERNATIONAL TRADE & EXHIBITION CENTRE (MITEC)

FIND US AT:

15 - 18 May 2024 | Hall 3, 3130

REVOLUCION TECHNOLOGY GROUP
Technology that transforms lives

CALL US
+6012-7727701

enquire@revoluciontech.com

www.revoluciontech.com

QR code to WhatsApp



MASSIVE FAN INDUSTRIES SDN BHD
BOOTH NO.: 8340



Belt Driven Axial Fan (MSBA Series) are designed for applications where the motor needs to be located outside of the air stream system. Specifically crafted for paint booth exhaust and other ventilation needs, our MSBA Series offers optimal performance and reliability.



BELT DRIVEN AXIAL FAN (MSBA SERIES)

MODU TECHNOLOGIES SDN BHD
BOOTH NO.: 6160

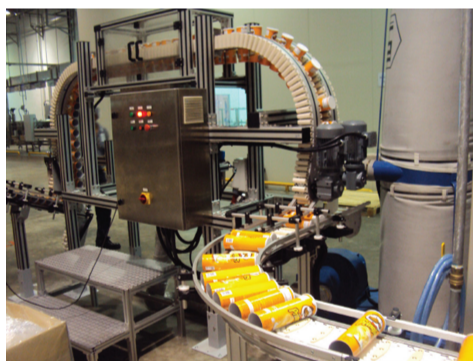

CONVEYORS & FACTORY AUTOMATION

We deliver tailored automated solutions for your manufacturing needs, utilizing our deep expertise and strong sales and service networks to enhance every stage of your production process.



NEPTRIX SDN BHD

BOOTH NO.: 6347

NEPTRIX FACVIEW INTERACTIVE DASHBOARD



Access your factory's operations with ease using nxFacview. Effortlessly track every detail of your factory's operations and stay informed with real-time updates. The stunning graphical dashboards provide a crystal-clear view of your production floor like never before, ensuring you are always in the loop.



DATA INTERACTION & VISUALIZATION
EASILY WITH NEPTRIX FACVIEW INTERACTIVE DASHBOARD

The constant moving production floor needs real-time, flexible Facview is not another ordinary dashboarding solution. It is tailored designed for manufacturers with state-of-the-art analytical technology, real-time in-depth feedback mechanism, factory-oriented graphical data representation. It is quick-to-implement, easy-to-use, that supports both on-premise and cloud-based. Making your data easily accessible anytime, anywhere!

Contact us now at sales@neptrix.com or visit www.neptrix.com for more details!



MITUTOYO

BOOTH NO.: 2100



MITUTOYO CNC CMM - CRYSTA-APEX V SERIES



MITUTOYO CNC CMM - CRYSTA-APEX V SERIES is part of a broad selection of precision measuring tools, ranging from basic tools like Micrometers, Calipers, and Indicators to more complex systems including Linear Height Gauges, Digital Scales and DROs, and sophisticated Data Management-SPC systems. Additionally, the series offers Hardness Testing Systems, FORM Measurements, and both Optical and 3D Coordinate Measuring Machines, and Vision Measuring Systems, ensuring robust solutions for all your precision measurement needs.

NCT TECHNOLOGIES SDN BHD

BOOTH NO.: 3360

ACCURL



Accurl produces high-quality Fiber Laser Cut Machines for the metal sheet, pipe, and H-beam industries. We also offer Auto Panel Benders, CNC Press Brakes, and Combi Laser-Punch machines as part of our supply pipeline. Our offerings are backed by experienced NCT's Engineers and come with comprehensive spare parts, Laser QC, and maintenance tools to ensure optimal performance and customer satisfaction.

NINGBO HAITIAN PRECISION MACHINERY CO., LTD.
BOOTH NO.: 4200

NINGBO HAITIAN PRECISION MACHINERY CO., LTD.



Introducing the Hison and Application Lines by Ningbo Haitian Precision, where cutting-edge technology meets precision engineering to redefine the very essence of manufacturing excellence. These exceptional lines represent the culmination of years of research, innovation, and expertise, offering a transformative solution for businesses seeking to stay at the forefront of their industries. Meet us at Booth 4200 at METALTECH & AUTOMEX!

METALTECH[®] automEX

Co-locating:

15 - 18 MAY 2024 MITEC, KUALA LUMPUR

SHOW DAILY



NOBLELIFT SOUTHEAST ASIA
BOOTH NO.: 8145

NOBLELIFT
Material Handling

FORKLIFT 25-35Q SERIES



FORKLIFT 25-35Q series is a cost-effective electric forklift that blends traditional internal combustion engine design with modern lithium-iron battery technology. It offers a spacious driving area and comfortable operation, making it ideal for a variety of tasks.

REVOLUCION TECHNOLOGY SDN BHD
BOOTH NO.: 3130



REVOLUCION TECHNOLOGY GROUP
Technology that transforms lives

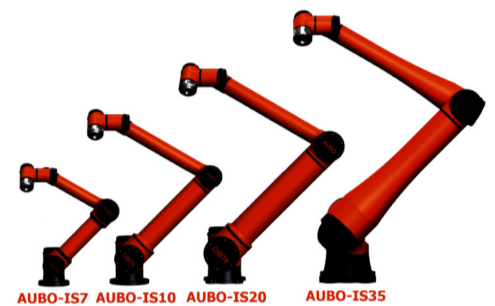

ROBOTIC AUTOMATION & INDUSTRIAL 4.0

Revolutionize Your Factory with Revolucion Technology: Your Premier Smart Factory and Cobot Solution Provider! Streamline operations, boost productivity, and embrace the future of manufacturing with our cutting-edge technology. Experience the power of automation and collaboration like never before.

SHANGHAI KAISEN ENVIRONMENTAL TECHNOLOGY CO., LTD
BOOTH NO.: 3115

KSZ 1.5S

The KSZ series mobile self-cleaning fume extractor is equipped with flexible suction arms and polyurethane casters, making it suitable for mobile use in different individual workstations. The suction arms can be freely moved, easily extended, and rotated a full 360 degrees for maximum flexibility and convenience.



STAUBLI SINGAPORE PTE LTD
BOOTH NO.: 7300

STÄUBLI

ELECTRICAL CONNECTORS, FLUID CONNECTORS AND ROBOTICS

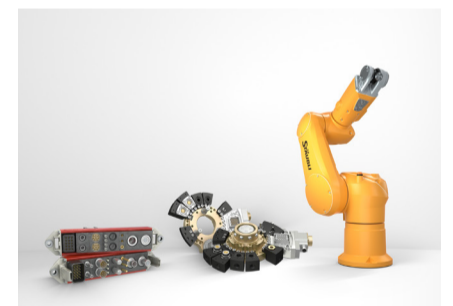

Explore Staubli's cutting-edge solutions in Electrical & Fluid Connectors and Robotics, driving productivity worldwide across diverse industries. With a workforce of 6,000 and a presence in over 50 countries, we've been your reliable partner in precision engineering solutions since 1892.

TSUGAMI

BOOTH NO.: 4350

PRECISION TSUGAMI

TSUGAMI CNC Precision Automatic Lathe, an advanced machining with unmatched precision and efficiency, perfect for high-volume production. Elevate your manufacturing with cutting-edge performance.



TSUGAMI CNC PRECISION AUTOMATIC LATHE

YUASA MECHATRONICS (M) SDN BHD
BOOTH NO.: 3180



TSUGAMI CNC LATHE MACHINE

Introducing the CNC Lathe Machine with Robot Automation, a perfect synergy of advanced technology. This machine is ideal for a wide range of applications, delivering high accuracy and productivity in machining operations. With the capability to hold 8 different tools, it offers unparalleled flexibility to accommodate various job requirements.

METALTECH® Co-locating: **automEX**

15 - 18 MAY 2024 **MITEC, KUALA LUMPUR**

SHOW DAILY



GERMANY PAVILION

AKE

BOOTH NO.: 4222

AKE
Cutting & better

Ferrous and non-ferrous metal cutting circular sawblades

AKE manufactures a range of ferrous and non-ferrous metal cutting circular saw blades in various sizes and specifications. These saw blades are designed to cater to a wide range of applications for both ferrous and non-ferrous metals.



Albrecht Präzision GmbH & Co.KG

BOOTH NO.: 4223



ALBRECHT SLIM5
Your power for 5 axes

ALBRECHT Precision Chucks

APC Slim5 chuck

Introducing the world's only Milling Chuck with a 1:16 worm gear and exceptional vibration damping. Experience it for yourself and see the difference!

ALD VACUUM TECHNOLOGIES

BOOTH NO.: 4243

AMG ENGINEERING **ald**

ALD Vacuum Technologies
High Tech is our Business

AMG ENGINEERING **ald**

Vacuum Metallurgy and Vacuum Heat Treatment

ALD Vacuum Technologies specializes in the manufacturing of vacuum furnaces for various applications, including melting, casting, powder making, and heat treatment. Our heat treatment systems are equipped with oil or gas quenching capabilities, ensuring efficient and precise heat treatment processes.



BLICKLE RÄDER + ROLLEN GMBH & CO. KG
BOOTH NO.: 4245

BLICKLE PRODUCT PORTFOLIO

Established in 1953, Blicke Germany is a family-owned global leader in the production of wheels and castors. With a wide range of over 30,000 products, we cater to loads of up to 50,000 kg. Since 2017, Blicke has been represented in Malaysia through its trusted partner.

Blicke
we innovate mobility



ACCURL Combi Laser-Punch Press

METALTECH[®] automEX

Co-locating:

15 - 18 MAY 2024 MITEC, KUALA LUMPUR

SHOW DAILY



GERMANY PAVILION

EMUGE-FRANKEN

BOOTH NO.: 4228



THREADING PRODUCTS AND ENDMILLS

With over 100 years of experience in the field of cutting tools, EMUGE-FRANKEN has established itself as a leader in producing high-performance tools of exceptional quality, all made in Germany. Our product range includes machine taps, thread mills, drills, gauges, milling tools, and workpiece clamping devices.

G&N GENAUIGKEITS MASCHINENBAU NURNBERG GMBH

BOOTH NO.: 4241



PRECISION SURFACE GRINDING MACHINE MPS R400 CM

Introducing our automatic precision surface grinding machine designed for pre- and finish grinding of metals and other materials in series production.

Key features include:

High-precision frequency-controlled rotary table, which can be adjusted for concave, convex, or parallel surfaces. Variable clamping options for enhanced flexibility. Low maintenance requirements, ensuring efficient operation.

GERMANY – FEDERAL MINISTRY FOR ECONOMIC AFFAIRS AND ENERGY

BOOTH NO.: 4240



Federal Ministry for Economic Affairs and Energy

GERMAN PAVILLION

Germany participates with a "German Pavilion" offering a professional brokerage service to help to establish contacts with German companies and comprehensive information on Germany as an important business location.

MEISTER

BOOTH NO.: 4242



FLOWMETER

The Meister float-type flowmeter is versatile and suitable for measuring various types of media, including water, oil, and gas. Its robust construction and cost-effectiveness make it an ideal choice for reliable monitoring of critical system flow volumes, particularly in applications such as lubrication and cooling.

KELCH GMBH

BOOTH NO.: 4221



KENOVA SET LINE V244 TOOL PRESETTER

KELCH KENOVA SET LINE V244 | TOOL PRESETTER

Introducing the first tool setting device on the market that operates without the need for compressed air. This compact and robust device is specifically designed for tools with a maximum diameter and length of 400 mm and a weight of up to 15 kg.

SCHUNK INTEC PTE LTD

BOOTH NO.: 4246



CMS

The CMS manual change system stands out with its user-friendliness, diverse range of modules, and extensive selection of accessories. It is highly versatile and can be utilized on robots as well as in stationary applications where tool changes are essential.

SCHÜSSLER

BOOTH NO.: 4227

HAWK EYE



SCHÜSSLER HAWK EYE[®]

Introducing SCHÜSSLER HAWK EYE[®], a solution that enables you to achieve precision and maximize the potential of your machine and tools. With high-precision concentricity features and robust clamping forces, it ensures highly efficient machining. Our latest addition is the HAWK EYE[®] ER-collet chucks "Mini," offering enhanced capabilities in a compact size.